

SPARK PLUG WIRES

Choice of spark plug wires is an important consideration when using an electronic ignition system. Use ONLY Resistor (CARBON CORE) or Approved Spiral Wound Spark Plug Wires & Resistor Spark Plugs. Solid or Spiral unapproved spiral wound wires will damage the ignition module and void the warranty!

SPARK PLUGS

You must use a resistor spark plug with electronic ignitions. Spark plug gap should be limited to as small as possible, while still maintaining performance.

A wide spark plug gap can cause the following problems: Hard cold starting, misfires during rich or lean fuel conditions, and reduction of upper rpm range.

Initial settings for spark plug gaps are:

Spark plug Multi-Spark 0.025-0.032

Many things effect spark plug gap settings:

Compression Ratio: The higher the engine compression, the more voltage required to fire the plug, and the narrower the plug gap should be.

RPM: The higher the rpm's the less time the coil has to charge to break over voltage or complete saturation. A narrower spark plug gap will help high rpm stability.

Multi-Spark: To maintain a good secondary spark within a wider rpm range it is wise to run a narrower spark plug gap. It is better to precisely place two stable, consistent sparks than to fire one wider spark that may cause misfires in rich or lean conditions, or from any of the above reasons.

Encoder (rotor) Installation and Cam end play

Cam end play should not exceed 0.020". The encoder disk should be fall the constraints of the optical pickup triggers.

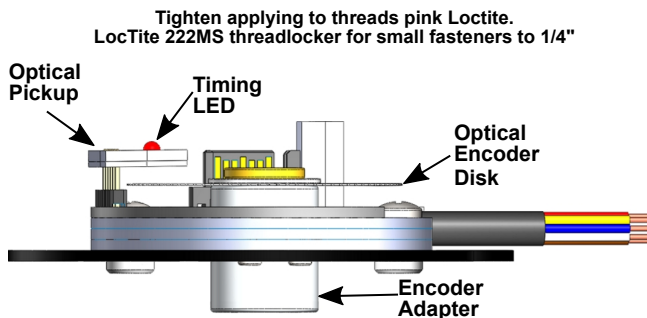

Optical Encoder Disk can not strike the Ignition Module or Optical Pickup at anytime during operation. Cam walk is normally outward so position Encoder Disk appropriately using shim washers.

OWNERS MANUAL

All information contained in this owner manual is the property of Power Arc Ignitions Co., Inc. and cannot be duplicated in whole or in part by any means or disseminated or distributed without the prior written consent of P. A. Ignitions Co., Inc. The information in this manual has been carefully compiled and checked for accuracy and is believed to be correct. However, P. A. Ignition Co., accepts no responsibility for inaccuracies which may occur. All specifications in this manual are subject to change without notice.

Power Arc Ignitions Co., Inc.
2518 N.E. 102 Ave.
Ankeny, IA 50021
(515) 964-7608

The following customer actions automatically voids the warranty.

1) Use of any other spark plug wires other than resistor type wires with at least 800 ohms of resistance. 2) Use of non-resistor spark plugs. 3) Drilling or cutting of any kind into the module. 4) Incorrect wiring of the module. 5) Use of module on systems with defective charging systems. 6) Use of defective or incorrect coils. 7) Directly shorting the coil output wires to +12 VDC. 8) Physical damage to the ignition. 9) Any other items covered in the warranty & instruction manual.

LIMITED WARRANTY

Power Arc Ignition Co., Inc. warrants to the original retail purchaser of a Power Arc IDS ignition that it will, free of charge, repair or replace at its own option, the product if returned to Power Arc Ignition Co., Inc. within 6 months after purchase and if found by Power Arc Ignition Co., Inc. to be defective in material or workmanship. This warranty is not transferable by the purchaser and shall be voided: if alterations not authorized by Power Arc Ignition Co., Inc. are made in the equipment or if the serial number or date of manufacture has been altered, defaced or removed. Nor does this warranty apply: if the equipment has been subjected to accident, misuse, improper hookup, damaged by flood, fire, or act of God, or has been used on circuits or voltages other than those indicated in its instruction manual. If the equipment is found to be defective in materials or workmanship the equipment will be returned and Power Arc Ignition Co., Inc. will pay the return shipping (this does not include next day shipping, second day shipping, shipments outside of the continental U. S. A. or shipments outside of the U.S.A.). All warranty work outside of the U.S.A. must include prepayment of return shipping. Customs, duties or tariffs are not covered by this warranty. If the equipment is found to be defective but is due to customer misuse (as described in warranty) Power Arc Ignition Co., Inc. will notify the customer and if the customer wants the defective equipment returned Power Arc Ignition Co., Inc. will return the equipment C.O.D. freight. If the equipment is found to be in operational order when returned to the factory Power Arc Ignition Co., Inc. will return the module with a \$30.00 service charge plus freight and C.O.D. Charges. Any module returned under the warranty must include note of explanation of failure and be accompanied by a dated bill of sale. Power Arc Ignition Co., Inc. warranty obligations are limited to those set forth herein and no other obligations, expressed or implied, are assumed by Power Arc Ignitions Co., Inc. Some states do not allow the exclusions or limitations of incidental or consequential damages, or allow limitations on how long an implied warranty lasts, so the above limitations or exclusions may not apply to you. This warranty gives you specific legal rights, and you may also have other rights which vary from state to state.

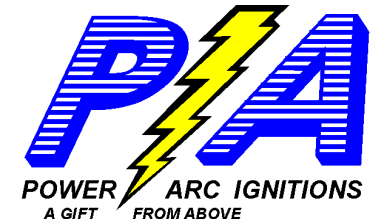

CD2-LM 90 12 Volt

British Twins
with 90° Crank

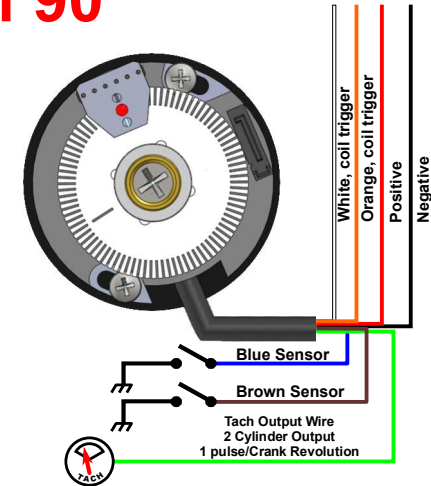

CD2-LM Ignition System

- Negative or Positive Ground Operation
- CW or CCW Cam Operation
- No External Module
- Low Voltage Operation
- Uses less Energy than Points Systems
- For 1 or 2 Cylinder Engine (with coil change)
- Multi-Spark 3 Sparks / Compression Stroke
- Automatic Coil Safety Shutoff
- Precision Rev limiter
- Static Timing Light
- Stainless Steel Encoder Disk
- Electronic Tach Output

POWER ARC IGNITIONS CO., INC.
2518 N. E. 102 AVE.
ANKENY, IA 50021
(515) 964-7608
<http://www.powerarc.com>
PATENT #4,951,629 OTHER PATENTS PENDING

Single Fire (Fires on Compress Only) 2 Cylinder, 1 Plug/Cylinder (Negative Ground)

Stop
Before wiring
disconnect
the power!!

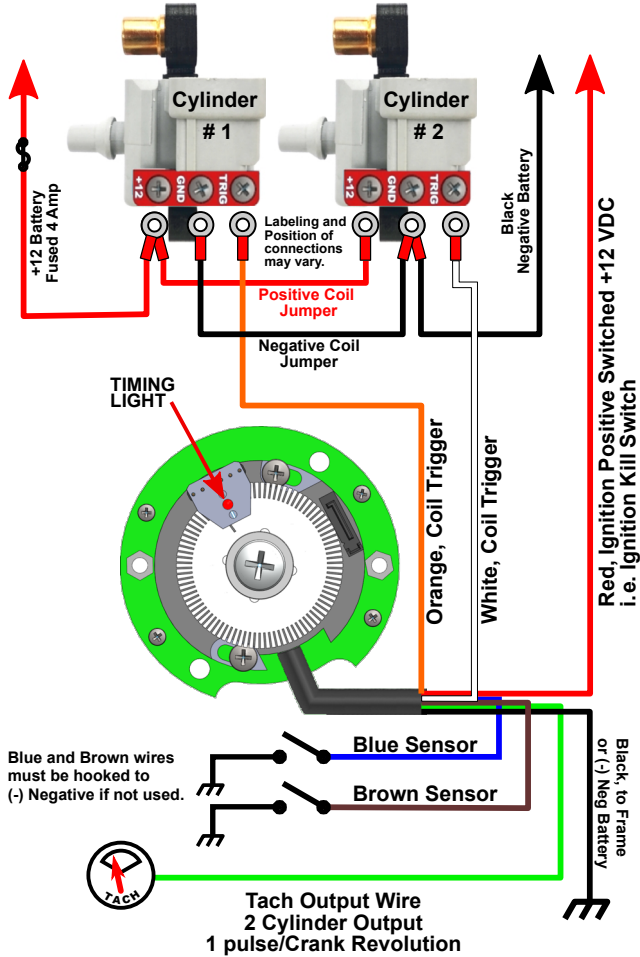

Tighten applying to threads pink Loctite.
Loctite 222MS threadlocker for small fasteners to 1/4"

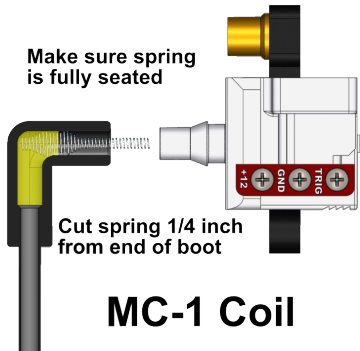

MC-1 Coil

WARNING: Do not touch coil output wires Orange or White to +12. DO NOT use Solid or Spiral wound suppression spark plug wires with less than 800 Ω per foot. DO NOT bundle module control wires with HV spark plug wires. DO NOT use with lithium ion batteries. Failure to observe these precautions will damage Ignition & Void the Warranty.

1. Turn the ignition/kill switch OFF. Remove and replace the existing ignition coil with a Power Arc Coil MC-1 or appropriate coil.
2. Remove all components from the ignition cam cover (points plate and flyweights), exposing the cam shaft end.
3. Insert ignition in place of the original points plate, with wires in best position to exit. Insert the Ignition hold down standoffs & tighten.
4. Select Positive or Negative Ground wiring use appropriate diagram.
Pos Ground: Connect Red wire of module to the coil selected + terminal post and to (+) Positive frame or battery Positive.
Neg Ground: Connect Red wire of module to switched (+) Positive from ignition/kill Switch. Connect the coil selected + terminal post to the (+) Positive battery terminal via a fuse placed close to the battery positive terminal.
5. Attach the Blue & Brown wires to (-) Negative for normal stock operation.
6. Hook the green wire to the tachometer trigger wire if used, if not used Isolate.
7. Insert the encoder adapter through the center hole of the ignition . Rest the optical encoder wheel centered on the Encoder Standoff. Place the stainless shim washer on to the step washer, push through the center of the Encoder Standoff. Using the existing flyweight screw or bolt apply pink 222MS Loctite to the screw and insert the hex head screw through the center of the adapter and lightly tighten (see diagram below).
8. Select Positive or Negative Ground wiring next and see diagrams.
Pos Ground: Connect Black (-) Negative wire of module to Switched (-) Negative from Kill Switch or Switched Power.
Neg Ground: Connect Black (-) Negative wire of module to the Frame or the battery Negative.
9. Choose a cylinder to be designated as #1 and rotate the engine to that cylinder's TOP DEAD CENTER COMPRESSION STROKE. If your engine does not have a cylinder Top Dead Center timing mark, it may be necessary to use a piston stop, dial indicator, degree wheel, or other appropriate method. Make a mark on crank to crank case for later reference.
10. Attach a Red jumper wire from the #1 cylinder terminal post (+12) to the #2 cylinder terminal post (+12). Attach a Black jumper wire from the #1 cylinder terminal post (NEG) to the #2 cylinder terminal post (NEG).
11. Put transmission in neutral, then power on the ignition module. Rotate the optical encoder in the opposite direction of cam rotation until the static timing LED lights and stop. Holding the optical encoder to prevent it from moving, tighten the adapter bolt. If encoder rotates when tightening causing LED to go out, fine tune by loosening module screws and rotating the module. Recheck top dead center to make sure the timing has not moved.
12. Connect the Orange Coil Trigger wire of module to (TRIG) of the coil designated as #1 cylinder. Connect the White wire to the coil (TRIG) of the other coil and it will be the cylinder #2 coil.
13. Place the spark plug wires to the appropriate cylinder, Orange triggered coil to cylinder # 1 and the white to triggered coil to cylinder # 2.
14. Turn the ignition/kill switch ON and start the engine.

NOTE: The stock bolt is used lock down the Encoder Adapter. Some aftermarket cams use a 1/4 x 28 SAE thread. If the bolt does not thread into the cam easily by hand, DO NOT USE A WRENCH TO TIGHTEN, since the cam may require a different bolt. Use care not to break the bolt off inside the cam. If you had a different aftermarket ignition installed the bolt may be incorrect in length and require the OEM bolt length.

Single Fire (Fires on Compress Only) 2 Cylinder, 1 Plug/Cylinder (Positive Ground)

Stop
Before wiring
disconnect
the power!!

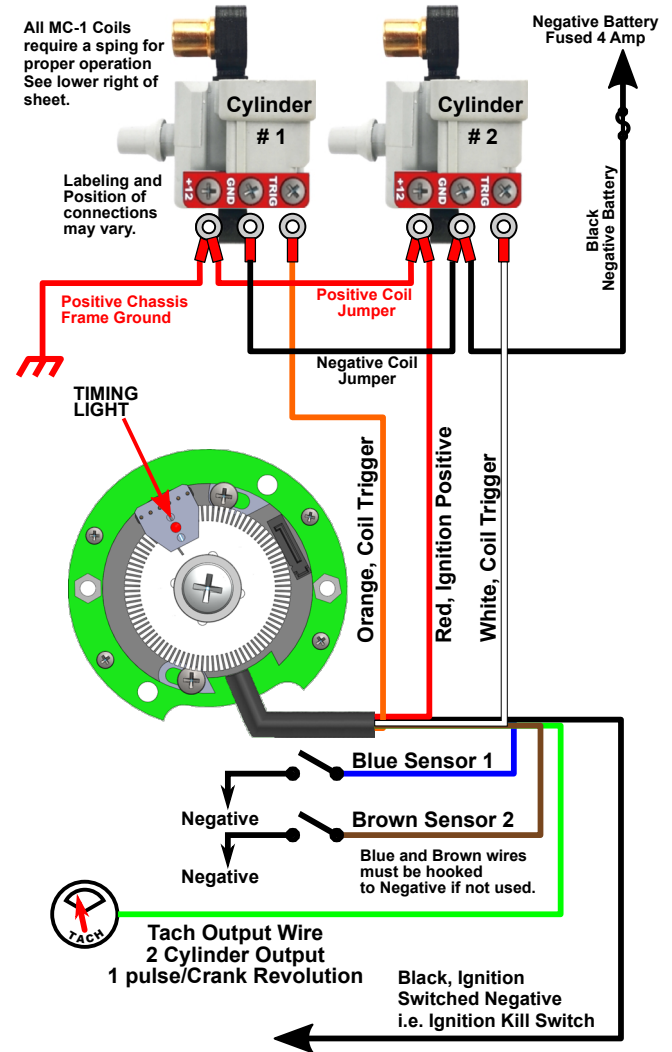

Determining #1 Cylinder

