

## SIMULATOR HOOKUP PROCEDURE

- 1) Make sure the motorcycle is in neutral and the ignition switch is off.
- 2) Remove the spark plugs from the engine and ground them to the frame.
- 3) Remove the trigger plate from the motorcycle and place it on the simulator platform using the rubber band to secure it.
- 4) Attach the simulator to a +12 VDC battery making sure to observe the proper polarity Red= (+) Black= (-). **If testing an in the cam cover ignition (EP<sup>2</sup>, CDS, CDR, or SR<sup>2</sup>) make sure to ground module with a jumper wire or ground clip.**
- 5) **Make sure VOES (blue wire) is grounded if applicable,** as the #4 step of the curve will not advance if not done.
- 6) **Arrange Saturation pin on simulator rotor for the type of module you are simulating, remove saturation pin if testing PAI or PAII.**
- 7) Turn on the ignition switch.  
Note: If setting a PA I, disconnect the coils (not the module) if you wish to run the simulator for over a few minutes.
- 8) Turn the adjustment knob of the simulator while observing the tachometer on bike and adjust to desired RPM setting. Turning adjustment screws CCW lower set point.
- 9) When adjustment is complete remove ground wire from VOES switch if used, install spark plugs & replace trigger plate.

### APPLICATION NOTES:

- 1) To test VOES blue wire operation disconnect the blue wire from ground and led advance indicator will go out showing a retard state.
- 2) To locate wiring problems set up simulator as described above and allow to run. Test connections by pulling gently on or moving all suspect connections i.e. grounds, positive and trigger wires.
- 3) If you have a MC I or II ignition you are testing, do not run for extended periods of time at low RPM's. Monitor coil temperature on a regular basis.
- 4) To test for high voltage leakage, set up simulator described above and allow to run. Using a long bladed, plastic handed screwdriver with a jumper wire attached from the blade to ground, grasp plastic handle and pass near spark plug wires and boots. You will get a spark to screwdriver blade if you have leakage.

**BENCH HOOKUP OF SIMULATOR:** Attach a 12 VDC battery or a 4 amp filtered powersupply (not a battery charger) to the ignition systems + 12 VDC input (red wire) and ground the electronic ignition module negative (black wire) & VOES (blue wire) **if applicable.** Hook up a tachometer to the tach trigger wire coming from the module. Coils do not need to be hooked up for the tach to work on PA-DS, CDR, CDS, EP<sup>2</sup> or SR<sup>2</sup> modules.



# POWER ARC MECHANICAL SIMULATOR

FOR DIAGNOSTICS OF POWER ARC  
ELECTRONIC IGNITION SYSTEMS

for

H-D and V-Twin Motorcycles

## TABLE OF CONTENTS

- **INSTALLATION & ADJUSTMENT**
- **SIMULATOR OPERATIONAL DRAWINGS**
- **WARRANTY**

**POWER ARC IGNITIONS, INC.**  
2518 N. E. 102 AVE.  
ANKENY, IA 50021  
(515) 964-7608

PATENT #4,951,629 OTHER PATENTS PENDING

## OWNERS MANUAL

All information contained in this owner manual is the property of P. A. Ignition Co., Inc. and cannot be duplicated in whole or in part by any means or disseminated or distributed without the prior written consent of P. A. Ignitions Co., Inc. The information in this manual has been carefully compiled and checked for accuracy and is believed to be correct. However, P. A. Ignition Co., accepts no responsibility for inaccuracies which may occur. All specifications in this manual are subject to change without notice.

**Power Arc. Ignitions Co., Inc.**  
2518 N.E. 102 Ave.  
Ankeny, IA 50021  
(515) 964-7608

## LIMITED WARRANTY

P. A. Ignition Co., Inc. warrants to the original retail purchaser of a Ignition simulator that it will be, free of charge, repair or replace at its own option, the product if returned to P. A. Ignition Co., Inc. within 6 months after purchase and if found by P. A. Ignition Co., Inc. to be defective in material or workmanship. This warranty is not transferable by the purchaser and shall be voided: if alterations not authorized by P. A. Ignition Co., Inc. are made in the equipment or if the serial number or date of manufacture has been altered, defaced or removed. Nor does this warranty apply: if the equipment has been subjected to accident, misuse, improper hookup, damaged by flood, fire, or act of God, or has been used on circuits or voltages other than those indicated in its instruction manual. If the equipment is found to be defective in materials or workmanship the equipment will be returned and P. A. Ignition Co., Inc. will pay the return shipping (this does not include next day shipping, second day shipping, shipments outside of the continental U. S. A. or shipments outside of the U.S.A.). All warranty work outside of the U.S.A. must include prepayment of return shipping. Customs, duties or tariffs are not covered by this warranty. If the equipment is found to be defective but is due to customer misuse (as described in warranty) P. A. Ignition Co., Inc. will notify the customer and if the customer wants the defective equipment returned P. A. Ignition Co., Inc. will return the equipment C.O.D. freight. If the equipment is found to be in operational order when returned to the factory P. A. Ignition Co., Inc. will return the module with a \$15.00 service charge plus freight and C.O.D. Charges.

**Any simulator returned under the warranty must include note of explanation of failure and be accompanied by a dated bill of sale.**

P. A. Ignition Co., Inc. warranty obligations are limited to those set forth herein and no other obligations, expressed or implied, are assumed by P.A. Ignitions Co., Inc.

Some states do not allow the exclusions or limitations of incidental or consequential damages, or allow limitations on how long an implied warranty lasts, so the above limitations or exclusions may not apply to you. This warranty gives you specific legal rights, and you may also have other rights which vary from state to state.

**WARNING: DO NOT HOOK IGNITION OR SIMULATOR TO BATTERY CHARGER!**

If module has VOES control wire, make sure VOES wire from module is GROUNDLED or #4 step of curve will not activate.

Remove saturation pin as needed for the type of module you are simulating.  
**PINS ARE FOR RPM SET POINTS ONLY.**

**PLACE IGNITION OR TRIGGER PLATE ON PLATFORM OF MECHANICAL SIMULATOR AND FASTEN WITH SUPPLIED BAND.**

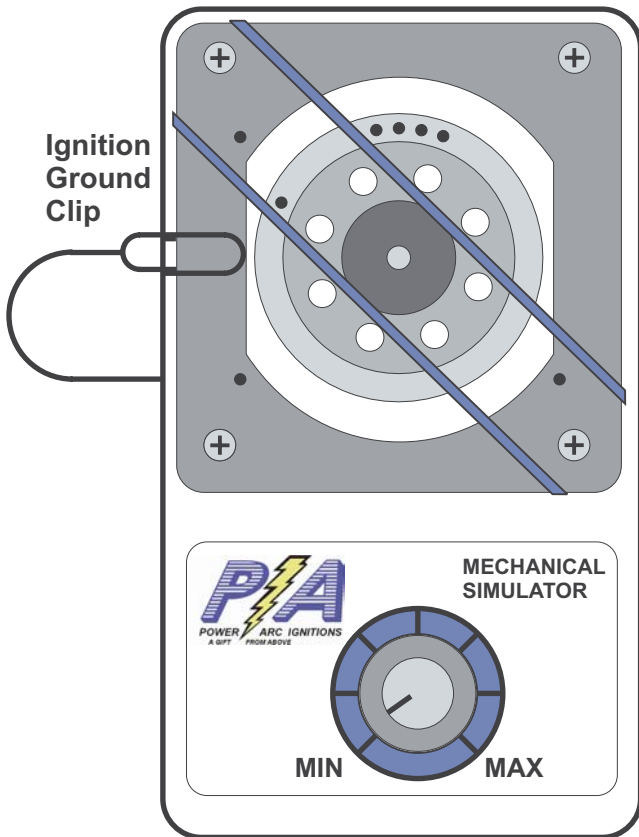

**WARNING**

DO NOT TOUCH COIL OUTPUTS (TRIGGER WIRES) TO +12 VDC. DO NOT USE SOLID (COPPER) IGNITION WIRES OR SPIRAL WOUND SUPPRESSION WIRES, USE RESISTOR WIRES ONLY. FAILURE TO OBSERVE THESE PRECAUTIONS WILL DAMAGE MODULE & VOID THE WARRANTY.

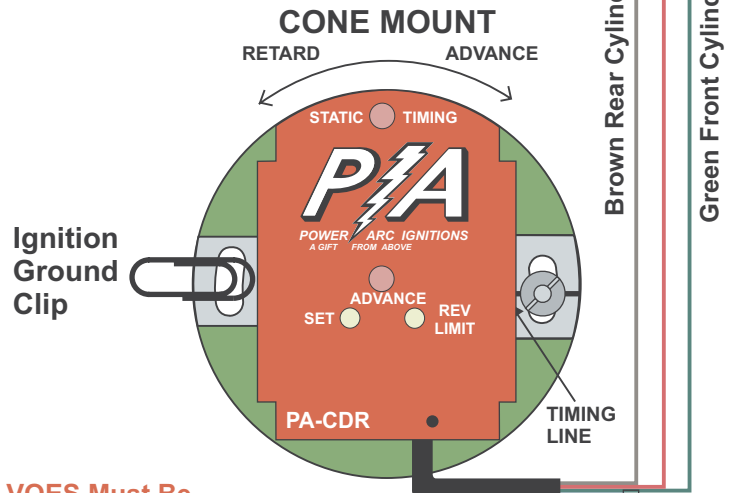
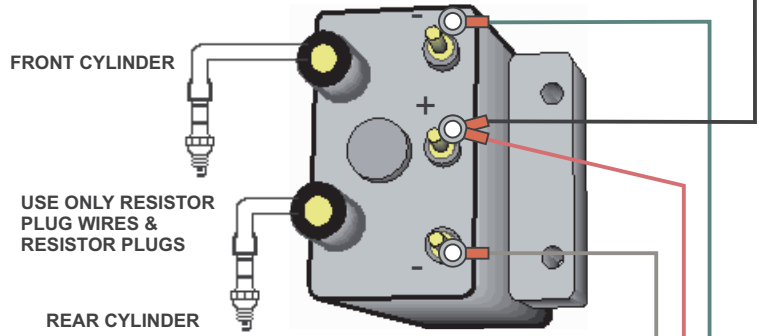
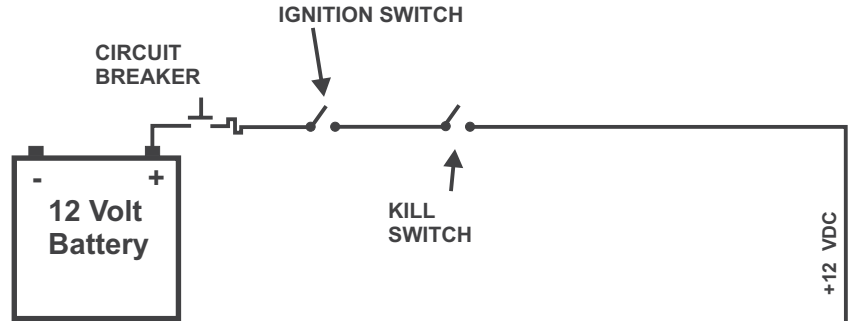

**VOES Must Be Grounded or Ignition will not Advance.**

VOES SHOULD BE ADJUSTED TO 5-5 1/2" lbs

