

SPARK PLUG WIRES

Choice of spark plug wires is an important consideration when using an electronic ignition system. **You must use carbon core resistor spark plug wires. If the wires are short and resistance is less than 4,000 ohms a resistor cap or boot is required. Solid or Spiral wound wires or wires with less than 4,000 ohms of resistance may damage the ignition module and void the warranty!**

SPARK PLUGS

You must use a resistor spark plug with electronic ignitions. Stock spark plugs are resistor type plugs and will work. Spark plug gap should be limited to as small as possible, while still maintaining performance.

A wide spark plug gap can cause the following problems: Hard cold starting, misfires during rich or lean fuel conditions, and reduction of upper rpm range.

Initial settings for spark plug gaps are:

Dual Fire -1 Plug per cylinder Multi-Spark 0.025"-0.032"

Many things effect spark plug gap settings:

Compression Ratio: The higher the engine compression, the more voltage required to fire the plug, and the narrower the plug gap should be.

RPM: The higher the rpm's the less time the coil has to charge to break over voltage or complete saturation. A narrower spark plug gap will help high rpm stability.

Multi-Spark: To maintain a good secondary spark within a wider rpm range it is wise to run a narrower spark plug gap. It is better to precisely place two stable, consistent sparks than to fire one wider spark that may cause misfires in rich or lean conditions, or from any of the above reasons.

Encoder Installation and Cam end play

Cam end play should not exceed 0.020"

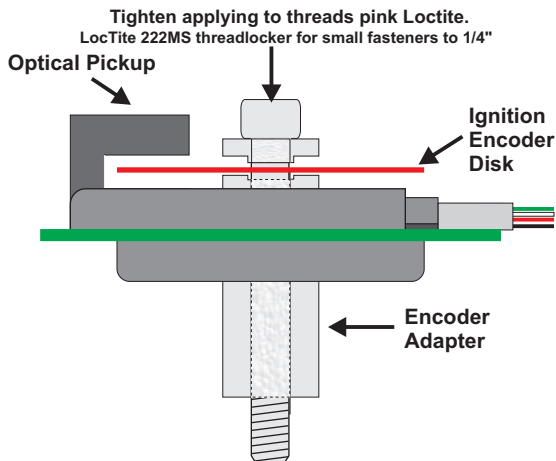

OWNERS MANUAL

All information contained in this owner manual is the property of P. A. Ignition Co., Inc. and cannot be duplicated in whole or in part by any means or disseminated or distributed without the prior written consent of P. A. Ignitions Co., Inc. The information in this manual has been carefully compiled and checked for accuracy and is believed to be correct. However, P. A. Ignition Co., accepts no responsibility for inaccuracies which may occur. All specifications in this manual are subject to change without notice.

Power Arc Ignitions Co., Inc.
2518 N.E. 102 Ave.
Ankeny, IA 50021
(515) 964-7608

The following customer actions automatically voids the warranty.

- 1) Use of any other spark plug wires other than resistor type wires with at least 3,000 ohms of resistance.
- 2) Use of non-resistor spark plugs.
- 3) Drilling or cutting of any kind into the module
- 4) Incorrect wiring of the module.
- 5) Use of module on systems with defective charging systems.
- 6) Use of defective coils.
- 7) Directly shorting the coil output wires to +12 VDC.
- 8) Physical damage to the ignition .
- 9) Any other items covered in the warranty & instruction manual.

LIMITED WARRANTY

P. A. Ignition Co., Inc. warrants to the original retail purchaser of a Power Arc IDS ignition that it will, free of charge, repair or replace at its own option, the product if returned to P. A. Ignition Co., Inc. within 6 months after purchase and if found by P. A. Ignition Co., Inc. to be defective in material or workmanship. This warranty is not transferable by the purchaser and shall be voided: if alterations not authorized by P. A. Ignition Co., Inc. are made in the equipment or if the serial number or date of manufacture has been altered, defaced or removed. Nor does this warranty apply: if the equipment has been subjected to accident, misuse, improper hookup, damaged by flood, fire, or act of God, or has been used on circuits or voltages other than those indicated in its instruction manual. If the equipment is found to be defective in materials or workmanship the equipment will be returned and P. A. Ignition Co., Inc. will pay the return shipping (this does not include next day shipping, second day shipping, shipments outside of the continental U. S. A. or shipments outside of the U.S.A.). All warranty work outside of the U.S.A. must include prepayment of return shipping. Customs, duties or tariffs are not covered by this warranty. If the equipment is found to be defective but is due to customer misuse (as described in warranty) P. A. Ignition Co., Inc. will notify the customer and if the customer wants the defective equipment returned P. A. Ignition Co., Inc. will return the equipment C.O.D. freight. If the equipment is found to be in operational order when returned to the factory P. A. Ignition Co., Inc. will return the module with a \$30.00 service charge plus freight and C.O.D. Charges.

Any module returned under the warranty must include note of explanation of failure and be accompanied by a dated bill of sale.

P. A. Ignition Co., Inc. warranty obligations are limited to those set forth herein and no other obligations, expressed or implied, are assumed by P. A. Ignitions Co., Inc.

Some states do not allow the exclusions or limitations of incidental or consequential damages, or allow limitations on how long an implied warranty lasts, so the above limitations or exclusions may no apply to you. This warranty gives you specific legal rights, and you may also have other rights which vary from state to state.

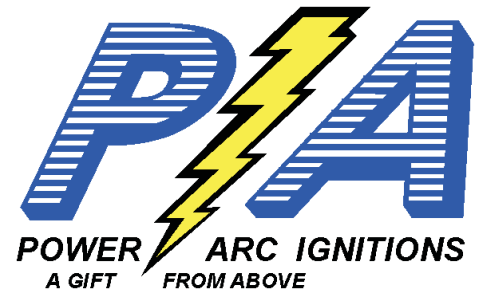

POWER ARC IDS-C1 HD OWNER'S MANUAL

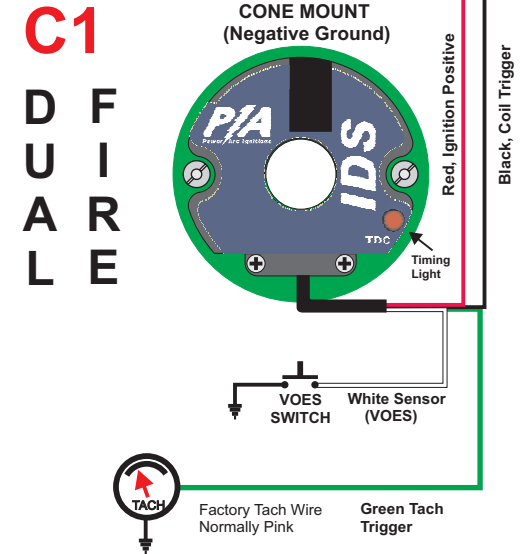

IDS-C1 HD Ignitions Systems

- Multi-Spark 3 Sparks / Compression Stroke
- Programmed Placement of Multi-Spark sparks
- Automatic Coil Shutoff
- Cam based sensor pickups
- Dual Fire Operation
- VOES Control Wire
- Precision Rev limiter
- Static Timing Light
- Stainless Steel Encoder Disk
- Corrected Tach Output

POWER ARC IGNITIONS CO., INC.
2518 N. E. 102 AVE.
ANKENY, IA 50021
(515) 964-7608

<http://www.powerarc.com>
PATENT #4,951,629 OTHER PATENTS PENDING

INSTALLATION INSTRUCTIONS

WARNING: Do not touch coil output wire (Black) To +12. DO NOT USE SOLID OR SPIRAL WOUND SUPPRESSION SPARK PLUG WIRES, USE RESISTOR WIRES ONLY. FAILURE TO OBSERVE THESE PRECAUTIONS WILL DAMAGE IGN. & VOID THE WARRANTY.

***See Encoder Installation and Cam end play on back page.**

1. Remove all components from the ignition cone cam cover area, exposing the cam shaft end. If you have a stock module leave it mounted in place, but disconnect it from the coil, tachometer and ignition switch wire.
2. Pull ignition wire through wire hole. Make sure not to run wiring near high heat areas of the motorcycle, such as the exhaust system. Rock ignition into cone, with the optical pickup at the top or in the case of a Sportster everything is rotated 90° clockwise with optical pickup facing forward and hold down screws in the vertical position.
Note: It is recommended you leave enough extra wire to allow the module to be removed from the cam cover for inspection and reprogramming, approximately, 6" minimum.
3. Insert the front and rear lock down screws & tighten.
4. Hook ignition positive (red) wire to the ignition supply, with the kill or ignition switch wire.
5. Hook the green wire to the tach trigger wire of motorcycle (usually pink) if used, if not used isolate.
6. Hook the White VOES wire to VOES switch.
Note: It is recommended that you use a VOES switch if one was on your motorcycle or you should add one if you have a high performance, heavy bike or have wide engine load variations. If you did not have a VOES ground the white wire.
7. Insert the Encoder adapter through the center of the hole of the ignition, step side out. Place the Optical Encoder centered on the step. Insert the hex head screw with bonded washer through the center of the adapter and lightly tighten, making sure the Optical Encoder is centered on the Adapter step.
8. Remove the timing plug and rotate the engine to **TOP DEAD CENTER FRONT CYLINDER COMPRESSION STROKE.** (see drawings at bottom of next page)
9. Turn the Ignition and Kill Switch on and rotate the Optical Encoder Counter Clockwise until the Static Timing LED lights and stop. Holding the Optical Encoder tighten the Adapter Hex screw firmly to hold the Encode wheel in place. Recheck top dead center timing mark to make sure the timing has not moved.
10. Hook the Black wire to the coil. Do not hook the white wire to positive. Some Harley-Davidsons use a white wire for positive.
11. Start the Engine.

**Do not Install Factory Cam Cover Lid with Rivets
Upper Rivet will Damage the Optical Pickup.**

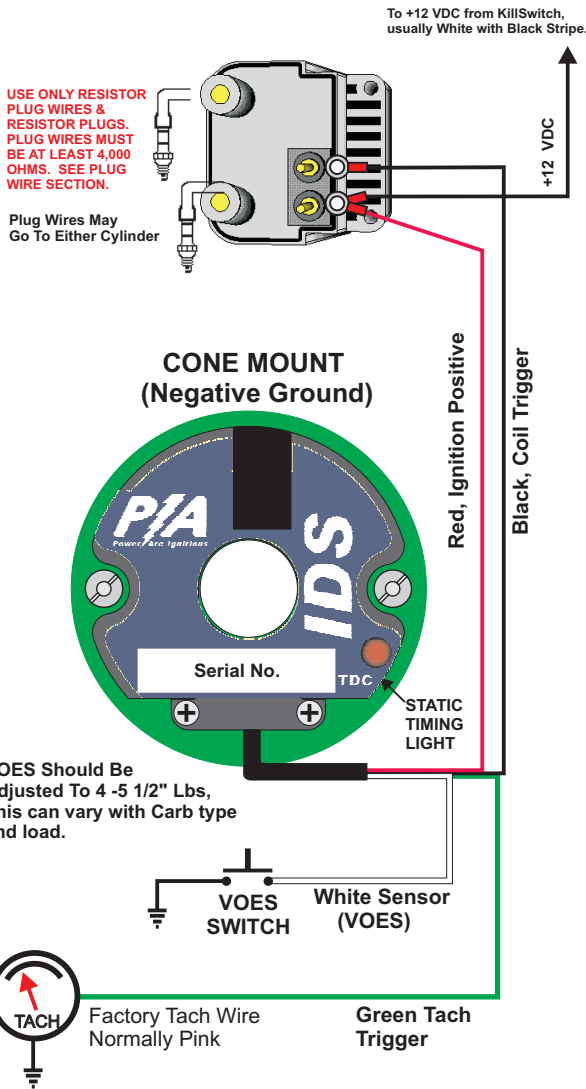
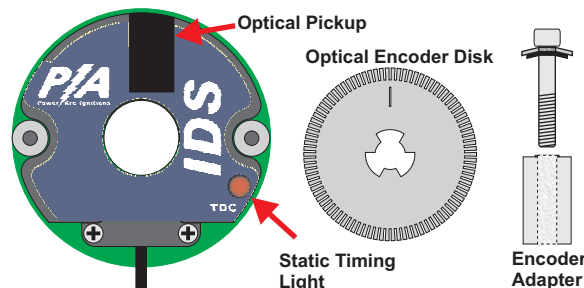

Spark Plug Wire Guidelines

1. Use only resistor (carbon core) spark plug wires & resistor spark plugs.
2. Do not use spiral wound suppression or solid type spark plug wires. If the plug wires are short and resistance is less than 4,000 ohms use a resistor plug cap/boot.
3. Failure to observe these precautions may cause ignition malfunction and could damage the ignition module or coil.

Coil Hookup Guidelines

1. Use of coils other than PA coils will result in loss of Multi-Spark capabilities.
2. Do not touch the Black coil output wire to +12 vdc.
3. A total of 2.8 ohms is the minimum allowable coil resistance.
4. Do not hook up coils with power (12 vdc) applied to the coils

COIL HOOKUP DRAWING

Dual Fire, 1 Plug/Cylinder, 3 Ohm, DF Coil

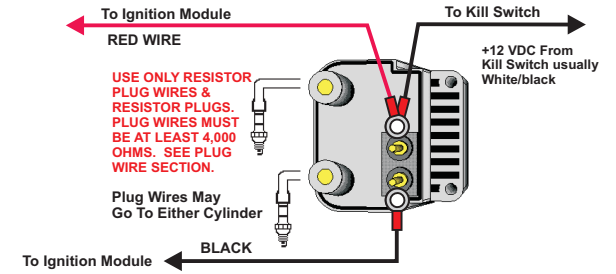

Dual Fire, 2 Plugs/Cylinder, 1.5 Ohm Coils
Power Arc does not have these coils and use of this style coil will effectively eliminate the Multi-Spark.

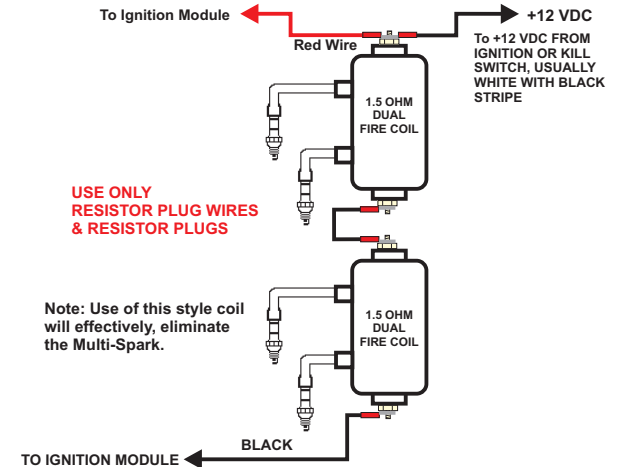

**Do not Install Factory Cam Cover Lid with Rivets
Upper Rivet will Damage the Optical Pickup.**

Locating TDC Front Cylinder Compression Stroke

Note: a Sportster is rotated 90° Clockwise

